

TECHNICAL DATA

PNEUMATIC TYRED ROLLERS

BW 11 RH-5

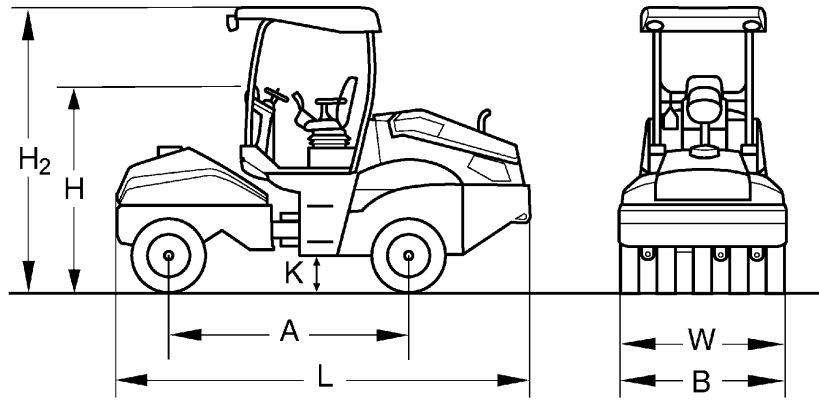



Dimensions in mm

	A	B	H	H₂	K	L	W
BW 11 RH-5	2500	1727	2085	2870	380	4430	1727

Shipping dimensions in m³

BW 11 RH-5

without ROPS

15,952

with ROPS

21,957

Machine type	Compaction output (t/h) at different asphalt layer thicknesses		
	2-4 cm	6-8 cm	10-12 cm
BW 11 RH-5	90-180	270-360	450-540

Technical Data

BOMAG BW 11 RH-5

Weights

Operating weight w. ROPS CECE	kg	5.200
Operating weight CECE w. ROPS-cabin	kg	5.400
Grossweight	kg	11.000
Max. middle wheel load CECE	kg	1.222

Dimensions

Track radius, inner	mm	3.100
---------------------------	----	-------

Driving Characteristics

Speed (1)	km/h	12,0
Speed (2)	km/h	16,0
Speed (3)	km/h	20,0
Max. gradeability (dep. on soil con.)	%	20

Drive

Engine manufacturer		Kubota
Type		V 3307 DI-T
Emission stage		Stage IIIa / TIER3
Cooling		Liquid
Number of cylinders		4
Performance ISO 14396	kW	55,4
Performance SAE J 1995	hp	74,0
Electric equipment	V	12
Drive system		hydrost.
Driven axles		rear

Tyres

Tyre size		7,50x15 14PL
Wheel track overlap	mm	> 20,0
Number of tyres, front / rear		5/4

Steering

Steering system		oscil.artic.
Steering method		hydrost.
Steering angle +/-	grad	35
Oscillating angle +/-	grad	10
Oscillation of tyres, front	grad	5

Capacities

Fuel	l	200,0
Water	l	530,0

Technical modifications reserved. Machines may be shown with options.

Standard Equipment

- Operator's platform with:
 - + Steering wheel
 - + Travel lever
 - + Operator seat
- Control panel for
 - Engine oil pressure
 - Engine temperature
 - Air filter vacuum
 - Hydraulic oil filter
 - Coolant level
 - fuel tank capacity
- Hour meter
- Warning horn
- Lockable anti vandal dashboard protection
- Back-up alarm

Optional Equipment

- * ROPS/FOPS with safety belt
- * ROPS-cabin with heating
- * ROPS cabin with air conditioning
- Radio
- Swivel seat (+40°/-10°)
- Indicator and hazard lights
- Rotary beacon
- Additional lighting for cabin
- Pointer
- Pressure sprinkler system/Scrapers
- Spraying system for scraper, coco fibre
- Spraying system for scraper, brush
- Central tyre inflating system
- Thermal aprons
- Brake release device
- Backup warning buzzer with broadband technology
- Special painting
- Additional weight
 - 7t Grossweight
 - 9t Grossweight
 - 11t Grossweight
- TELEMATIC

* Standard delivery with CE conformity
(valid within European Union)

