

# TECHNICAL DATA

TANDEM ROLLERS

BW 154 AP-5, BW 174 AP-5

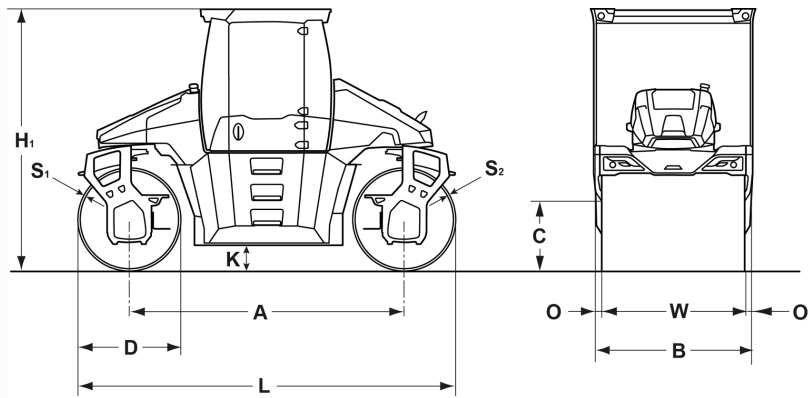



**Dimensions in mm**

	<b>A</b>	<b>B</b>	<b>C</b>	<b>D</b>	<b>H1</b>	<b>K</b>	<b>L</b>	<b>O</b>	<b>S</b>	<b>W</b>
<b>BW 154 AP-5</b>	2890	1680	790	1100	3020	260	3990	90	16	1500
<b>BW 174 AP-5</b>	3220	1860	790	1200	3050	280	4420	90	17	1680

**Shipping dimensions in m3**

<b>BW 154 AP-5</b>	20,244
<b>BW 174 AP-5</b>	25,075

<b>Machine type</b>	<b>Compaction output (t/h) at different asphalt layer thicknesses</b>		
	<b>2-4 cm</b>	<b>6-8 cm</b>	<b>10-14 cm</b>
BW 154 AP-5	30-60	60-130	80-160
BW 174 AP-5	50-110	90-180	140-210

**Technical Data****BOMAG  
BW 154 AP-5****BOMAG  
BW 174 AP-5****Weights**

Operating weight CECE w. ROPS-cabin .....	kg	7.100	9.600
Axle load, front / rear CECE .....	kg	3.550/3.550	4.800/4.800
Static linear load, front / rear CECE .....	kg/cm	23,7/23,7	28,6/28,6
Max. weight .....	kg	8.700	10.700

**Dimensions**

Track radius, inner .....	mm	2.950	2.970
---------------------------	----	-------	-------

**Driving Characteristics**

Speed .....	km/h	0- 11,0	0- 11,0
-------------	------	---------	---------

**Drive**

Engine manufacturer .....		Kubota	Deutz
Type .....		V3307 -T	TCD 3.6
Emission stage .....		Stage V / TIER4f	Stage V / TIER4f
Exhaust gas aftertreatment .....		DOC+DPF	DPF+SCR
Cooling .....		Liquid	Liquid
Number of cylinders .....		4	4
Fuel .....		Diesel	Diesel
Performance ISO 14396 .....	kW	55,4	74,4
Performance SAE J 1995 .....	hp	74,2	99,6
Speed .....	min-1	2.400	2.200
Split drum .....		front + rear	front + rear

**Brakes**

Service brake .....		hydrost.	hydrost.
Parking brake .....		mech.	mech.

**Steering**

Steering system .....		2-p. pivoted	2-p. pivoted
Lateral displacement right/left .....	mm	1.130	1.360

**Exciter system**

Frequency .....	Hz	47/55	47/60
Amplitude .....	mm	0,66/0,32	0,55/0,30
Centrifugal force .....	kN	96/63	92/70

**Sprinkler System**

Type of sprinkling .....		pressure	pressure
--------------------------	--	----------	----------

**Capacities**

Fuel .....	l	180,0	180,0
Water .....	l	550,0	680,0

Technical modifications reserved. Machines may be shown with options.

### Standard Equipment

- ECOMODE
- Water-saving pressure sprinklers
- 10" Touchscreen
- Individual vibration control
- 2 amplitudes / 2 frequencies
- Autom. vibration operation
- 4 spring-loaded hinged scrapers
- Indicator and hazard lights
- ROPS cabin with seat belts
  - + heating
- 2 Outside mirrors
- Steering method/Operator's seat sliding / rotatable (270°)
- Steering with comfort control
  - 5 Steering modes
- Back-up alarm
- Emergency STOP
- Brake release device
- Split drums

### Optional Equipment

- ECONOMIZER
- Edge cutter
- Rotary beacon
- Special paint
- Environmentally compliant hydraulic oil
- Tool kit
- Precision spreader
- Precision spreader laterally slidable
- Automatic air conditioning
- Radio/Radio preparation
- LED lighting package
  - additional lateral lighting for cabin
  - Follow-me-home function
  - Lighting for drum edge
  - 2x 12V sockets in supports
- Backup warning buzzer with broadband technology
- Additional outside mirrors
- Air-suspended comfort seat
- BOMAG TELEMATIC POWER
- BOMAG ECOSTOP
- BOMAP compaction navigation with GPS
- JOBLINK measuring technology interface
- BOMAP GPS antenna set
- BOMAP GPS antenna holder

