

TECHNICAL DATA

SINGLE DRUM ROLLERS

BW 211 D-5, BW 211 PD-5

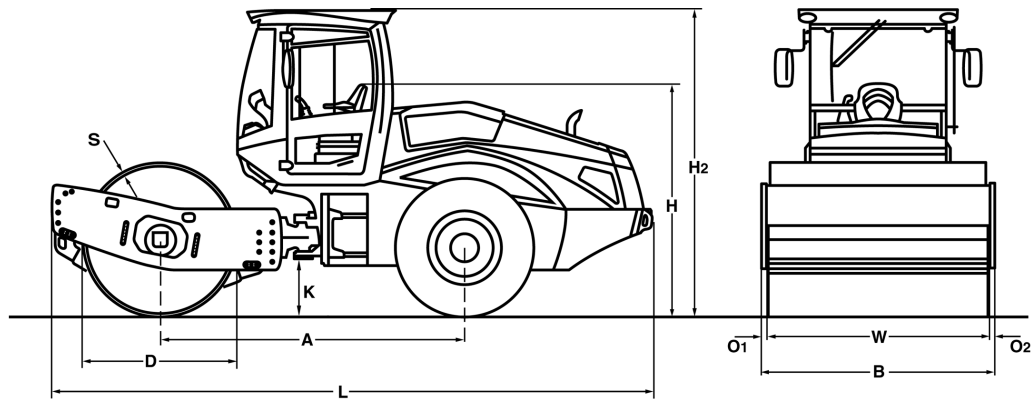



Dimensions in mm

	A	B	D	H	H2	K	L	O1	O2	S	W
BW 211 D-5	2975	2270	1500	2260	2990	490	5870	70	70	25	2130
BW 211 PD-5	2975	2270	1480	2260	2990	490	5870	70	70	25	2130

Shipping dimensions in m3

BW 211 D-5
BW 211 PD-5

without ROPS

30,114
30,114

with ROPS

39,841
39,841

Machine type	Compaction output (m3/h)			
	Rock fill	Gravel, sand	Mixed soil	Silt, clay
BW 211 D-5	400-800	270-540	220-440	110-220
BW 211 PD-5	400-800	270-540	220-440	160-320

Machine type	Compacted layer thickness (m)			
	Rock fill	Gravel, sand	Mixed soil	Silt, clay
BW 211 D-5	0,70	0,50	0,40	0,20
BW 211 PD-5	0,70	0,50	0,40	0,25

Technical Data**BOMAG
BW 211 D-5****BOMAG
BW 211 PD-5****Weights**

Grossweight	kg	12.890	12.750
Operating weight CECE w. ROPS-cabin	kg	10.600	12.100
Axle load, drum CECE	kg	5.670	7.170
Axle load, wheels CECE	kg	4.930	4.930
Static linear load CECE	kg/cm	26,6	

Dimensions

Working width	mm	2.130	2.130
Track radius, inner	mm	3.680	3.680

Driving Characteristics

Speed (1)	km/h	0- 5,0	0- 5,0
Speed (2)	km/h	0- 6,0	0- 6,0
Speed (3)	km/h	0- 8,0	0- 8,0
Speed (4)	km/h	0- 11,0	0- 11,0
Max. gradeability without/with vibr.	%	51/48	54/51

Drive

Engine manufacturer		Deutz	Deutz
Type		TCD 3.6 L4	TCD 3.6 L4
Emission stage		Stage V	Stage V
Exhaust gas aftertreatment		DOC+DPF+SCR	DOC+DPF+SCR
Cooling		Liquid	Liquid
Number of cylinders		4	4
Performance ISO 3046	kW	95,0	95,0
Performance SAE J 1995	hp	128,0	128,0
Speed	min-1	2.000	2.000
Fuel		Diesel	Diesel
Electric equipment	V	12	12
Drive system		hydrost.	hydrost.
Drum driven		standard	standard

Drums and Tyres

Number of pad feet			150
Area of one pad foot	cm ²		137
Height of pad feet	mm		100
Tyre size		23.1-26 12PR	23.1-26 12PR

Brakes

Service brake		hydrost.	hydrost.
Parking brake		hydromec.	hydromec.

Steering

Steering system		oscil.artic.	oscil.artic.
Steering method		hydrost.	hydrost.
Steering / oscillating angle +/-	grad	35/12	35/12

Exciter system

Drive system		hydrost.	hydrost.
Frequency	Hz	30/34	30/34
Amplitude	mm	1,95/1,00	1,70/0,90
Centrifugal force	kN	240/158	285/194
Centrifugal force	t	24,5/16,1	29,1/19,8

Capacities

Fuel	l	220,0	220,0
------------	---	-------	-------

Technical modifications reserved. Machines may be shown with options.

Standard Equipment

- BOMAG ECOMODE
- Self locking differential
- Rear axle with twin spring accumulator brakes
- Hydrostatic travel and vibration drive
- Hydrostatic articulated steering
- Articulated joint lock
- Seat with arm rest and adj. for position and height
- Battery disconnect switch
- Single lever control for travel and vibration
- Warning, information and operation displays with LCD
- Loading mode
- Emergency STOP
- Working lights front / rear
- Back-up alarm
- 2 Scrapers
- Warning horn

Optional Equipment

- * ROPS/FOPS cabin with seat belts
 - Sliding window
- ROPS/FOPS with safety belt
- Rearview camera
- Air condition
- Radio (Bluetooth)
- Pre start cabin heating
- Comfort package: Adjustable seat and adjustable steering column
- Rotary beacon
- Indicator and hazard lights
- BOMAG ECOSTOP
- ECONOMIZER
- TERRAMETER
- BOMAG TELEMATIC POWER
- Special painting
- Padfoot segment kit (D)
- Environmentally compliant hydraulic oil
- Measuring- and machine data interface for third-party suppliers
- LED Working lights (Cabin)
- Reversing alarm buzzer with broad band audio

* Standard delivery with CE conformity
(valid within European Union)

