



TECHNICAL DATA

PNEUMATIC TYRED ROLLERS

BW 28 RH



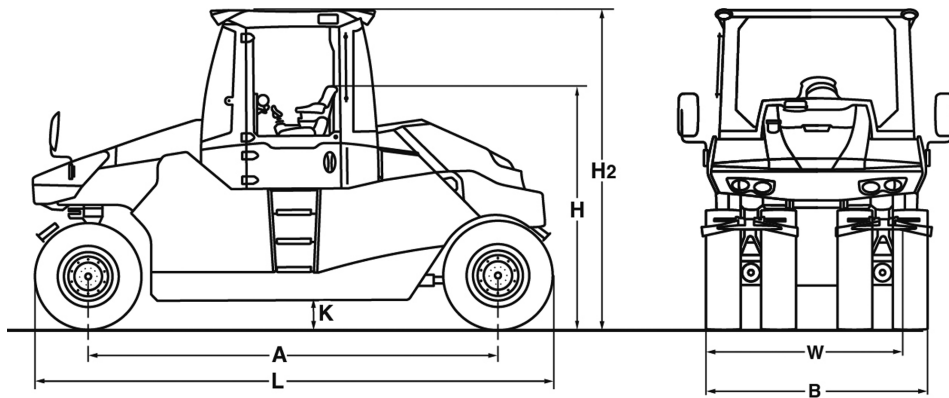

Dimensions in mm

	A	B	H	H2	K	L	W
BW 28 RH	3875	2070	2287	3050	280	4945	2042

Shipping dimensions in m3

BW 28 RH

without ROPS

23,410

with ROPS

31,220

Machine type	Compaction output (m3/h) (layer thickness) at recommended soil layer thicknesses		
	Silt, clay (0,20 m)	Gravel, sand (0,30 m)	Mixed soil (0,25 m)
BW 28 RH	120-150	120-200	80-180

Machine type	Compaction output (t/h) at different asphalt layer thicknesses		
	2-4 cm	6-8 cm	10-12 cm
BW 28 RH	30-80	60-100	80-150

Technical Data

BOMAG BW 28 RH

Weights

Operating weight CECE w. ROPS-cabin	kg	8.600
Grossweight	kg	28.000
Max. middle wheel load CECE	kg	3.500

Dimensions

Track radius, inner	mm	5.700
---------------------------	----	-------

Driving Characteristics

Speed (1)	km/h	0- 19,0
Max. gradeability (dep. on soil con.)	%	27

Drive

Engine manufacturer		Deutz
Type		TCD 3.6 L4
Emission stage		Stage IV / TIER4f
Exhaust gas aftertreatment		DPF+SCR
Cooling		Liquid
Number of cylinders		4
Performance ISO 14396	kW	100,0
Performance SAE J 1995	hp	134,0
Speed	min-1	2.000
Electric equipment	V	12
Drive system		hydrost.
Driven axles		rear

Tyres

Tyre size		11,00-20 18PR
Wheel track overlap	mm	32,0

Brakes

Service brake		hydrost.
Parking brake		multi disc

Steering

Steering system		2-p. pivoted
Steering method		hydrost.
Steering angle +/-	grad	30
Oscillation of tyres, front	grad	4
Level adjustment	mm	100

Sprinkler System

Type of sprinkling		pressure
--------------------------	--	----------

Capacities

Fuel	l	200,0
Water	l	340,0
Volume of ballast compartment	m3	3,0

Technical modifications reserved. Machines may be shown with options.

Standard Equipment

- Operator's platform with:
 - Steering wheel
 - Travel lever with multi-functional arm rest
 - Rotable and laterally sliding seat (-70°/+15°)
- Control panel for
 - Speedometer
 - Engine oil pressure
 - Engine temperature
 - Air filter vacuum
 - Charge control
 - Hydraulic oil filter
 - Coolant Level
 - fuel tank capacity
 - Sprinkler system - tank capacity
 - Hour meter
- Warning horn
- 2 Outside mirrors
- Indicator and hazard lights
- Working lights
- BOMAG ECOMODE
- Spraying system and scraper
- Back-up alarm
- Cold start device
- Service diagnostics tool

Optional Equipment

- * ROPS/FOPS with safety belt
- * ROPS-cabin with heating
- * ROPS cabin with air conditioning
- Temperature display
- Fire extinguisher
- Rearview camera
- Rotary beacon
- Additional lighting for cabin
- Radio Bluetooth
- Additive spraying system
- Central tyre inflating system
- Scraper coco mat, spring loaded and tiltable
- Scraper brush, spring loaded and tiltable
- Thermal aprons
- Profiled tyres
- Wheels MICHELIN 13/80R20
- Wheels DUNLOP 11,00-R20
- Waterproof frame
- Additional weight
 - Max. ballast 10t
 - Max. ballast 10t Flex
 - Max. ballast 12t
 - Max. ballast 12t Flex
 - Max. ballast 16t
 - Max. ballast 16t Flex
 - Max. ballast 18t
 - Max. ballast 20t
 - Max. ballast 24t
 - Max. ballast 28t
- Special painting
- Broadband buzzer
- BOMAG TELEMATIC
- Tool kit

* Standard delivery with CE conformity
(valid within European Union)#72

