

TECHNICAL DATA

COLD PLANERS (TIER 3)
BM 1000/35-2, BM 1200/35-2, BM 1300/35-2

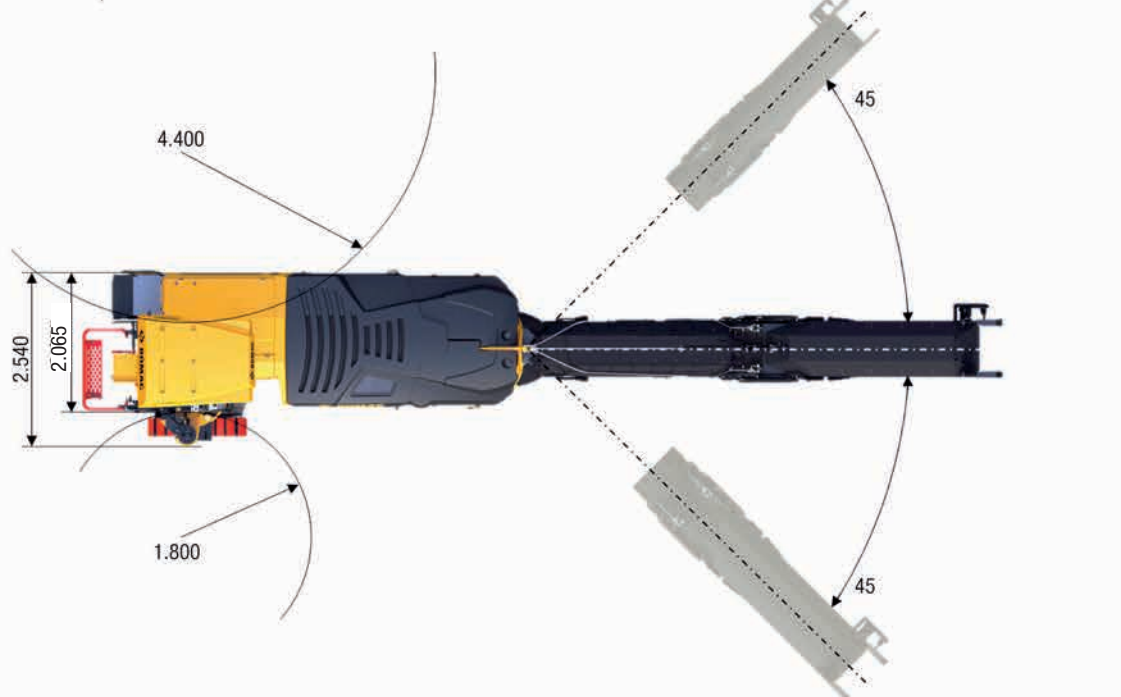

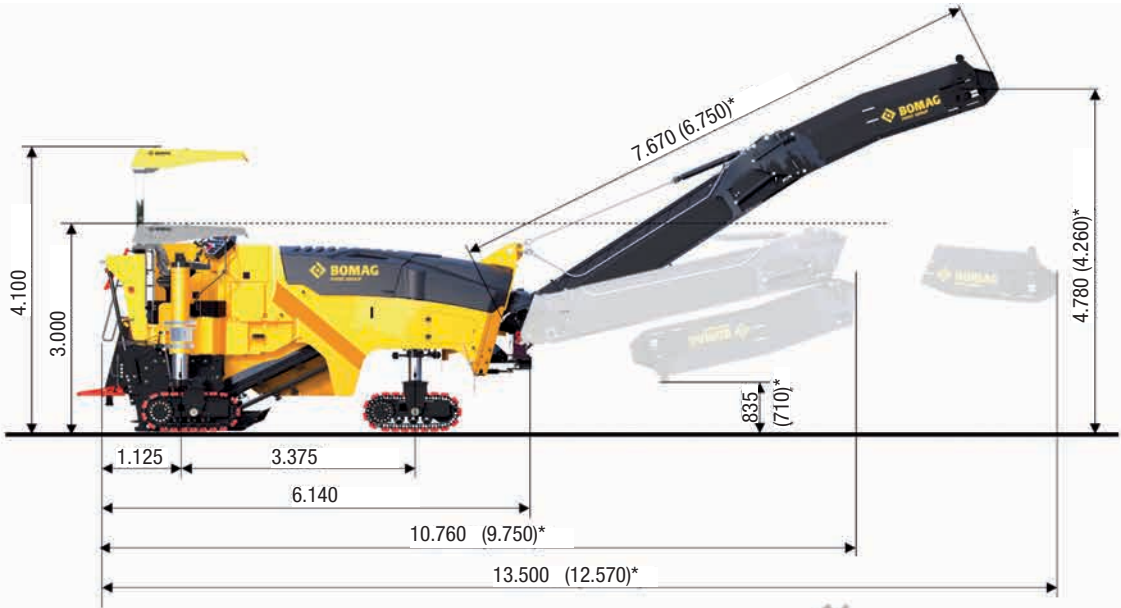

BM 1200 & BM 1300



* FO22

Technical data

Milling drum

	BOMAG BM 1000/35-2	BOMAG BM 1200/35-2	BOMAG BM 1300/35-2
Milling width max	1000	1200	1300
Milling depth	0–330	0–330	0–330
Milling line distance	15	15	15
Cutting diameter	980	980	980
Number of cutting tools	99	115	121
Milling speed	variable, 85, 95 and 107	variable, 85, 95 and 107	variable, 85, 95 and 107

Drive

Engine manufacturer	MTU (Mercedes)	MTU (Mercedes)	MTU (Mercedes)
Type	Series 1000 6R	Series 1000 6R	Series 1000 6R
Exhaust classification	TIER 3	TIER 3	TIER 3
Cooling system	Fluid	Fluid	Fluid
Number of cylinders/displacement	6/7,700	6/7,700	6/7,700
Power	240/326	240/326	240/326
Rated speed	2200	2200	2200
Max. torque	1400	1400	1400
Fuel consumption at nominal power	215	215	215
Fuel consumption with the construction mix	26	26	26
Generator	28/150	28/150	28/150
Battery	2 x 12 / 155	2 x 12 / 155	2 x 12 / 155

Travel characteristics

Travel speed	0–7.5	0–7.5	0–7.5
Working speed	0–50	0–50	0–50
Track chains, L x W x H	1425 x 268 x 570	1425 x 268 x 570	1425 x 268 x 570

Filling capacities

Fuel	600	600	600
Water	1400	1400	1400
Hydraulic system	180	180	180

Loading system

Width of conveyor belt, inner/outer	650/600	650/600	650/600
Theoretic loading capacity	180	180	180
Discharge height	5700	5700	5700

Machine weights

Max. operating weight (incl. options)	24	25	25.5
Operating weight CECE	20.4	21.4	21.9
Basic weight	19.4	20.4	20.9

Extra weights options

Weather protection roof	205	205	205
Dust extraction	140	140	140
Scraper, split	200	200	200
Quick-change milling drum	110	120	130
Fine milling drum LA8	300	300	300
Ballast 1, frame	1150	1030	1030
Ballast 2, milling box	440	440	440

Technical modifications reserved. Machines may be shown with options. The actual machine weight depends on the respective configuration.

Standard equipment

Milling technology

- Milling drum LA15
- BOMAG BMS 15 exchange holder system
- 3 Milling drum speeds
- Proportionally adjustable water quantity
- Automatic water saving detection
- Water filling pump
- Wear-free, digital milling depth indicator
- Proportional milling depth adjustment
- Two proportional height adjustment speed ranges
- Hydraulically operated side plates
- Hydraulically operated hold-down
- Scraper with adjustable scraper pressure
- Right-hand side plate for quick milling drum changes
- Automatic power limit control
- Automatic traction control
- Hydraulically foldable discharge belt

Drives

- Track chain drive with 4 chains
- Swivel mechanism: Full automatic swivelling of the rear right chain with 5000 hrs./ 60 M warranty
- Steered rear right chain
- Infinitely variable transport speed range
- Infinitely variable milling speed
- Mechanical milling drive

Ease of operation

- Fully vibration-isolated driver's stand
- Comfortable work area for operation from a seated position
- Ergonomic comfort seat, which can be rotated 45° in two directions
- Ergonomically adjustable steering column
- Height-adjustable arm rest with an integrated control unit
- Self-explanatory and clearly arranged control panel
- Spacious storage compartments at ground level
- High performance 3-way water pump
- Group placement of service and maintenance points
- Secure and conveniently accessible service and maintenance points

Safety & environmental protection

- Package for noise elimination to a whisper-quiet level
- Water-cooled engine of the latest

Exhaust classification

- Variably positionable optional head lights
- Flashing beacon
- Rear-view mirror
- Backup protection
- Vandal-proof covers for the control units

Optional equipment

Basic machine

- Weather protection roof
- High pressure cleaner
- Dust extraction
- ION DUST SHIELD
- Auxiliary drive for tool change
- StvZO lighting
- Optional head lights, attachable
- Optional head lights, magnetic base
- Ballasting
- Seat heating
- Special paintwork
- Biodegradable hydraulic oil
- Hydraulically folding discharge belt, short
- Maintenance seat
- Access ladder
- Storage package
- Holder package for shovel, spray can, etc.

Milling technology

- Milling drum 600 LA15
- Milling drum 900 LA15
- Milling drum 1000 LA15
- Milling drum 1200 LA15
- Milling drum 1300 LA15
- Fine milling drum 1000 LA8
- Fine milling drum 1200 LA8
- Fine milling drum 1300 LA8
- Fine milling drum 1000 LA6x2
- POWER DRUM 1000 LA22
- POWER DRUM 1200 LA22
- POWER DRUM 1300 LA22
- Split scraper
- Counter bearing for SW milling drum

Levelling systems and electronic aids

- BOMAG Easy Level; levelling, 2 sides + cross slope
- Mechanical height indicator on the rear lifting columns
- Camera surveillance
- BOMAG TELEMATIC

